

Application

- It can be used to transfer clean water or other liquids similar to water in physical and chemical properties. It is suitable for small living water supply, automatic water sprinkler system, small air conditioner system or supporting equipment etc.

Pump

- Cast iron pump body and support under special anti-rust treatment
- Rust-free copper inserts prevent impeller's block when starting after the pump is unused for a long time
- Brass impeller with evenly arranged radial vanes
- AISI 304 shaft
- Max. liquid temperature: +60°C
- Max. suction: +8 m

Motor

- C&U bearing
- Motor with copper winding
- Built-in thermal protector for single phase motor
- Insulation class: F
- Protection class: IPX4
- Max. ambient temperature: +40°C

Identification Codes

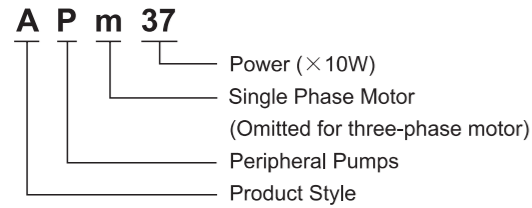

Technical Data

MODEL		POWER		Q (m ³ /h)																
Single Phase	Three Phase	kW	HP	0	0.3	0.6	0.9	1.2	1.5	1.8	2.1	2.4	3.0	3.6	4.2	4.8	5.4			
				Q (l/min)																
				0	5	10	15	20	25	30	35	40	50	60	70	80	90			
APm30	AP30	0.3	0.4	30	26	20	15	12	8	5	2									
APm37	AP37	0.37	0.5	40	35	30	25	20	15	10	5	2								
APm60	AP60	0.6	0.8	60	55	50	40	35	30	25	20	10	5							
APm75	AP75	0.75	1.0	75	70	60	50	45	35	28	22	15	5							
APm90	AP90	0.75	1.0	90	75	60	50	35	25	15	5									
APm110	AP110	1.1	1.5	85	80	75	65	60	55	50	45	40	30	18	10					
APm150	AP150	1.5	2.0	90	86	80	75	70	65	60	55	50	40	30	20	10				
—	AP220	2.2	3.0	100	96	90	85	80	75	70	65	60	50	40	30	20	10			

Dimension

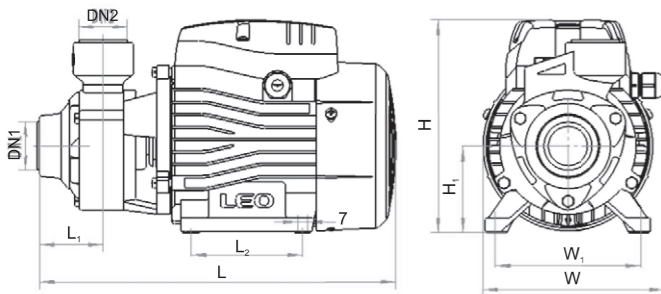

MODEL	DN1	DN2	L (mm)	W (mm)	H (mm)	L ₁ (mm)	L ₂ (mm)	W ₁ (mm)	H ₁ (mm)
APm30			260	132	155	46.5	80	100	63
APm37			260	132	155	46.5	80	100	63
APm60	1"	1"	282	147	183	51	90	112	71
APm75			300	147	183	54.5	90	112	71
APm90	3/4"	3/4"	289	147	183	50	90	112	71
APm110			336	165	210	56	100	125	86
APm150	1"	1"	338	165	210	56	100	125	86
AP220			338	165	210	56	100	125	86

Hydraulic Performance Curve

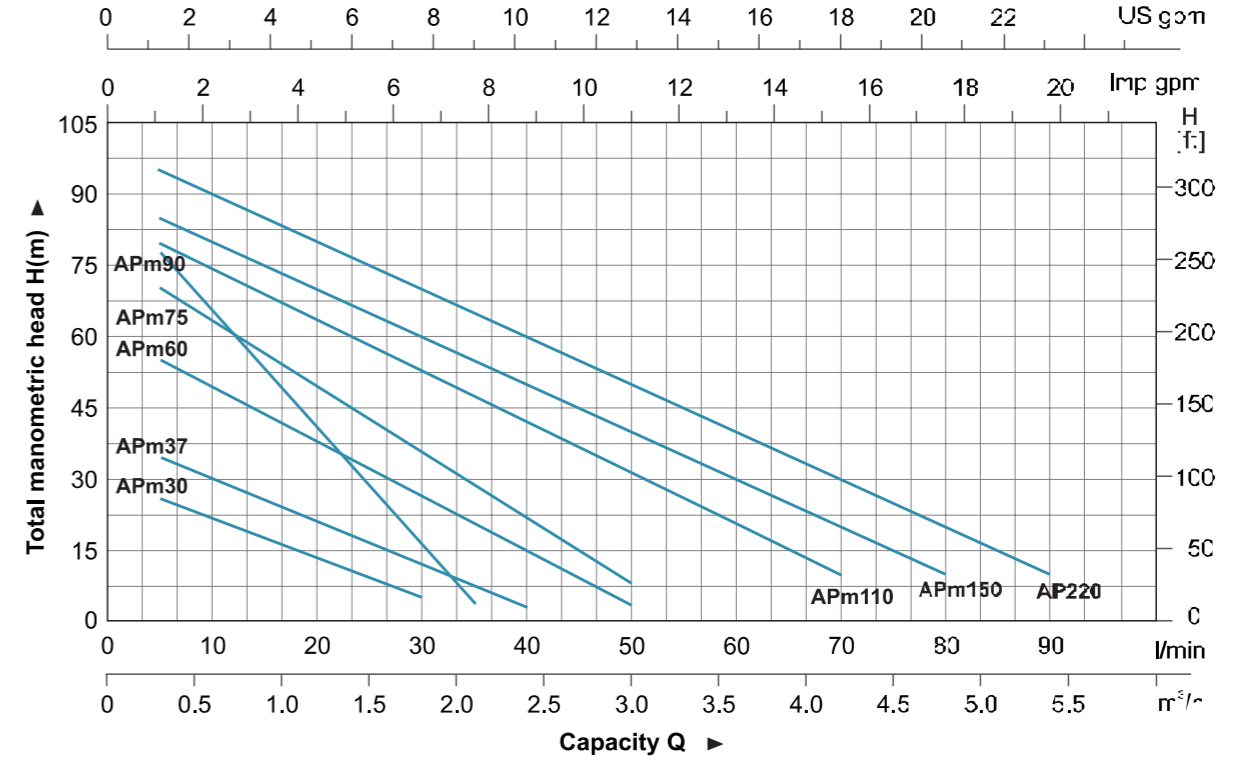

Materials Table

No.	Part	Material
1	Pump body	HT200
2	Impeller	ZCuZn38
3	Mechanical seal	Carbon/ceramic
4	O-ring	NBR
5	Support	HT200
6	Bearing	
7	Rotor	
8	Fan cover	PP
9	Fan	PP
10	End plate	ZL102
11	Capacitor	
12	Capacitor box	ABS
13	Terminal board	PC
14	Stator	
15	Filling plug	HPb59-1

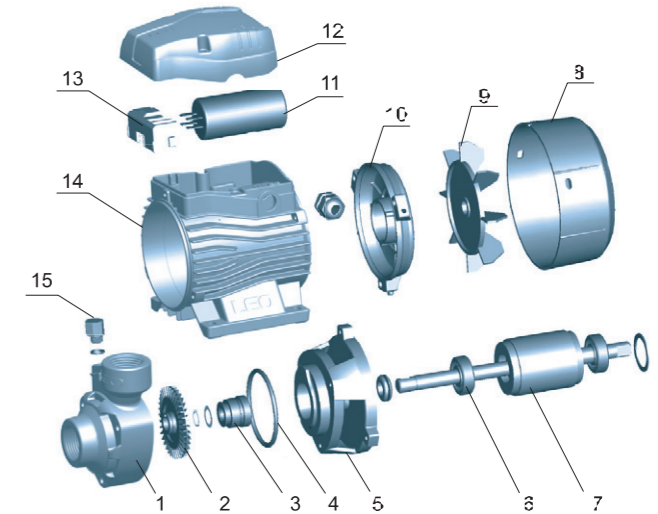

Package Information

Model	GW (Kgs)	L (mm)	W (mm)	H (mm)	Quantity (PCS/20 TEU)
APm30	5.1	283	158	174	3132
APm37	5.5	283	158	174	3132
APm60	9.0	330	190	210	2365
APm75	10.5	345	190	210	2222
APm90	10.5	345	190	210	2222
APm110	15.9	360	210	250	1230
APm150	16.5	360	210	250	1230
AP220	17.2	360	210	250	1230